



EOS-MLE60-24DC-UD

Constant Voltage LED Driver



Class 2 Electronic UNV 5 in 1 dimming

Outdoor Black Powder Coated Steel Enclosure

Single Circuit: **24VDC**

Total Wattage: **60W max**

Input Voltage: **100-277V 50/60Hz**

Transformer

Dimmable with triac forward and reverse phase, 0/1-10V , resistor, PWM

Input leads are 18AWG 600V

Output leads are 16AWG 300V

Leads max. operational temperature is 105°C

Housing

The actual transformer 60W is encapsulated in the enclosure

The enclosure is Black Powder Coated Steel, NEMA 3R rated

Wiring compartment has 6 knockouts sizes for 3/8 inch screw cable connectors

Enclosure Temperature does not exceed 70°C at 45°C ambient and fully loaded

Dimensions (inch): H = 4.47, W = 6.79, D = 1.38

Weight (LBs): 1.8

Electrical Parameters

Input Voltage:	100-277V 50/60Hz
Max. input current at full load:	0.6A
Output voltage without load:	24.1VDC
Output voltage fully loaded:	24VDC
Max. Total Wattage:	60W
Max. Output Current:	2.5A
Efficiency:	87%
Load regulation:	1%
Ripple:	5%

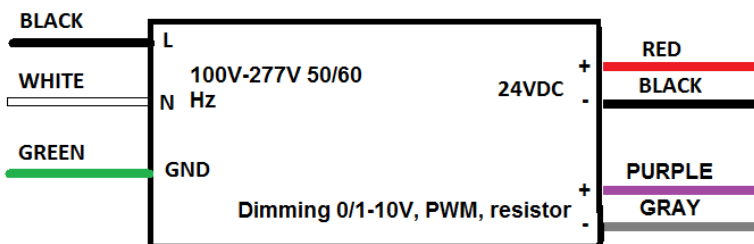
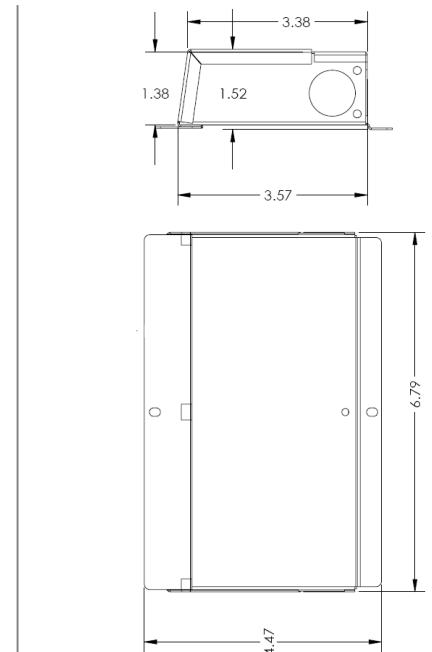

Conforms to UL STD. 8750 and 1310
Certified to CSA
STD. C22.2 No 250.0
model EOS-MLE60-24DC-UD



Installation Instructions

EOS-MLE60-24DC-UD

Class 2 Electronic UNV 5 in 1 dimming
Outdoor Black Powder Coated Steel
Enclosure Single Circuit: 24VDC
Total Wattage: 60W max
Input Voltage: 100-277V 50/60Hz



- * Read instruction completely before installation.
- * Turn off electricity before wiring.
- * Only qualified personal should install the unit
- * Installation must comply with the NEC.
- * Ensure the unit has input, output voltage and output wattage proper for your application.

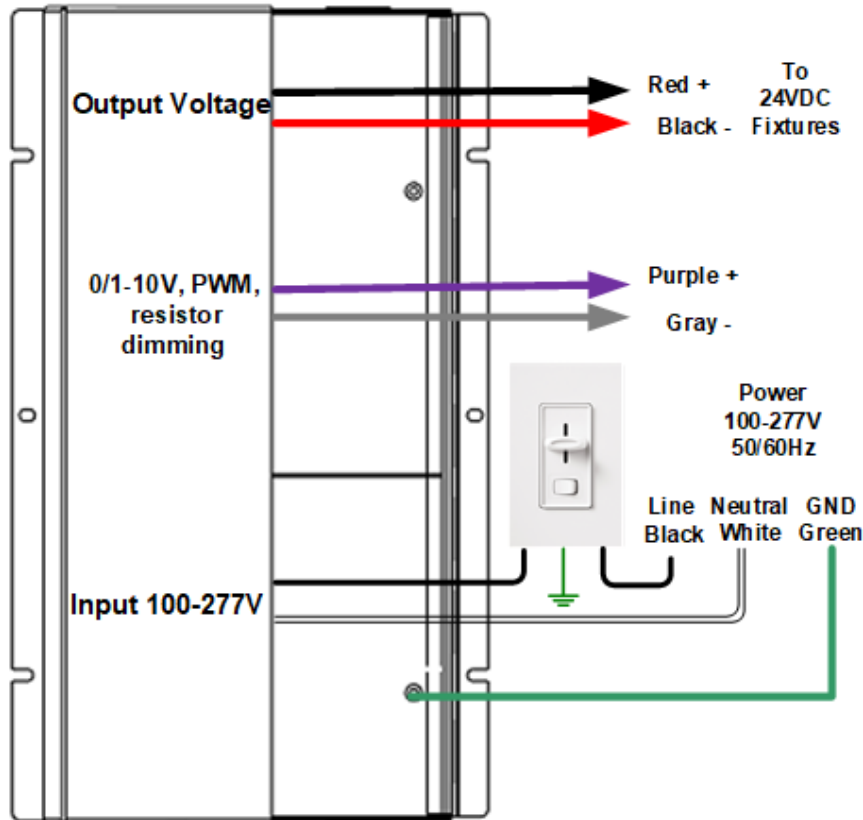

Mounting

The transformer must be mounted in at least 5" of a free flow air space for proper ventilation.
The transformer must never be mounted next to or above heat radiated objects.
The maximum ambient temperature should not exceed 45 deg. C (115 deg. F) at full load.

Connection

Open the wire compartment and remove knockouts for input and output, install strain reliefs (wire clamps). Use only right size and UL approved wire nuts.

Input Connection

Bring your line and neutral wires through input strain relief and connect them to the Black and White transformers leads.

Dimming

If you are going to use dimmer, connect it as on diagram. If you going to use 0/1-10V, PWM dimmer or resistor, connect it to Purple- and Gray +. You porew connect directly to the driver.

Output Connection

Bring your lights wires through output strain relief and connect to the Red + and Black - transformer leads. **Make sure all your connection very tight**

Grounding

The LED Driver is grounded to the enclosure. The enclosure in turn should be grounded in accordance with NEC and local code. Connect the transformer green wire to the ground.



Conforms to UL STD. 8750 and 1310
Certified to CSA
STD. C22.2 No 250.0
Model EOS-MLE-60-24DC-UD